

INTERNATIONAL STANDARD

ISO 3069

Second edition
2000-11-01

End-suction centrifugal pumps — Dimensions of cavities for mechanical seals and for soft packing

*Pompes centrifuges à aspiration en bout — Dimensions des logements de
garnitures mécaniques et de tresses*



Reference number
ISO 3069:2000(E)

© ISO 2000

PDF disclaimer

This PDF file may contain embedded typefaces. In accordance with Adobe's licensing policy, this file may be printed or viewed but shall not be edited unless the typefaces which are embedded are licensed to and installed on the computer performing the editing. In downloading this file, parties accept therein the responsibility of not infringing Adobe's licensing policy. The ISO Central Secretariat accepts no liability in this area.

Adobe is a trademark of Adobe Systems Incorporated.

Details of the software products used to create this PDF file can be found in the General Info relative to the file; the PDF-creation parameters were optimized for printing. Every care has been taken to ensure that the file is suitable for use by ISO member bodies. In the unlikely event that a problem relating to it is found, please inform the Central Secretariat at the address given below.

© ISO 2000

All rights reserved. Unless otherwise specified, no part of this publication may be reproduced or utilized in any form or by any means, electronic or mechanical, including photocopying and microfilm, without permission in writing from either ISO at the address below or ISO's member body in the country of the requester.

ISO copyright office
Case postale 56 • CH-1211 Geneva 20
Tel. + 41 22 749 01 11
Fax + 41 22 749 09 47
E-mail copyright@iso.ch
Web www.iso.ch

Printed in Switzerland

Contents

	Page
Foreword.....	iv
1 Scope	1
2 Normative references	1
3 Terms and definitions	1
4 Specification of dimensions of seal cavity and seal gland plate attachments	3
4.1 Dimensions of stuffing box and seal cavity attachments for general-purpose duties (designated ISO 3069-S).....	3
4.2 Dimensions of seal cavity and seal gland plate attachments for heavy-duty process applications (designated ISO 3069-H)	5
5 Design requirements for seal cavities	7
5.1 Vent and drain	7
5.2 Squareness and concentricity of surfaces	7
Annex A (informative) Dimensions of cavities for cartridge mechanical seals for general-purpose duties (designated ISO 3069-C).....	8
Bibliography	10

Foreword

ISO (the International Organization for Standardization) is a worldwide federation of national standards bodies (ISO member bodies). The work of preparing International Standards is normally carried out through ISO technical committees. Each member body interested in a subject for which a technical committee has been established has the right to be represented on that committee. International organizations, governmental and non-governmental, in liaison with ISO, also take part in the work. ISO collaborates closely with the International Electrotechnical Commission (IEC) on all matters of electrotechnical standardization.

International Standards are drafted in accordance with the rules given in the ISO/IEC Directives, Part 3.

Draft International Standards adopted by the technical committees are circulated to the member bodies for voting. Publication as an International Standard requires approval by at least 75 % of the member bodies casting a vote.

Attention is drawn to the possibility that some of the elements of this International Standard may be the subject of patent rights. ISO shall not be held responsible for identifying any or all such patent rights.

International Standard ISO 3069 was prepared by Technical Committee ISO/TC 115, *Pumps*, Subcommittee SC 1, *Dimensions and technical specifications of pumps*.

This second edition cancels and replaces the first edition (ISO 3069:1974), which has been technically revised by having a broadened scope and the inclusion of an alternative heavy-duty seal cavity. The previously published cavity dimensions have not been amended, but the sizes available have been increased. To meet the growing demand for cartridge mechanical seals, an informative annex has been included to assist in the rationalization of seal cavity dimensions for this product group. The dimensional recommendations have been applied to seal chambers with parallel bores, although reference is made, where appropriate, to the equivalent performance of conical shaped seal chambers.

Annex A of this International Standard is for information only.

End-suction centrifugal pumps — Dimensions of cavities for mechanical seals and for soft packing

1 Scope

This International Standard specifies the dimensions of the seal cavity for step-balanced mechanical seals, mechanical seals suitable for straight shafts, and for soft packing, to be used with horizontal end-suction centrifugal pumps, including those conforming to ISO 2858. Although applicable to general-purpose and heavy-duty process applications, this International Standard is not intended for use in processes with slurries or with high levels of solids.

This International Standard offers two options:

- a) a range of stuffing boxes suitable for soft packing or mechanical seals for general-purpose duties up to a seal chamber limit of a gauge pressure of 16 bar;
- b) a range of larger cavities suitable for mechanical seals, including cartridge mechanical seals, for general and heavy-duty process applications, up to a seal chamber limit of a gauge pressure of 40 bar.

2 Normative references

The following normative documents contain provisions which, through reference in this text, constitute provisions of this International Standard. For dated references, subsequent amendments to, or revisions of, any of these publications do not apply. However, parties to agreements based on this International Standard are encouraged to investigate the possibility of applying the most recent editions of the normative documents indicated below. For undated references, the latest edition of the normative document referred to applies. Members of ISO and IEC maintain registers of currently valid International Standards.

ISO 5199, *Technical specifications for centrifugal pumps — Class II.*

ISO 9905, *Technical specifications for centrifugal pumps — Class I.*

ISO 9908, *Technical specifications for centrifugal pumps — Class III.*

EN 12756, *Mechanical seals — Principal dimensions, designation and material codes.*

3 Terms and definitions

For the purposes of this International Standard, the following terms and definitions apply.

3.1

cartridge mechanical seal

a completely self-contained unit (including mechanical seal, gland plate, sleeve, and mating ring), pre-assembled and preset before installation

3.2

flush

flow of fluid introduced into the seal cavity on the process fluid side, in close proximity to the sealing faces, and usually used for cooling the mechanical seal and continuously removing vapour and/or contaminants from the seal cavity

3.3

gland face

mounting arrangement and equipment surface to which the seal gland plate is clamped

NOTE This is normally the seal end of the seal chamber.

3.4

seal cavity

fluid-filled space contained by the seal chamber

NOTE The mechanical seal rotates in the seal cavity.

3.5

seal chamber

component, either integral with or separate from the pump case, forming the containment between the shaft and casing

NOTE The mechanical seal is installed in the seal chamber.

3.6

seal gland plate

end plate connecting the stationary assembly of a mechanical seal to the seal chamber

3.7

spigot

male part of a joint used for accurate radial location of two machined components

3.8

stuffing box

cylindrical seal chamber, designed for the use of soft packing, for the purpose of reducing leakage along the shaft

3.9

total axial run-out tolerance

tolerance zone limited by two parallel planes, a defined distance apart, and perpendicular to the shaft datum axis

NOTE It can be measured by securing a dial indicator to the shaft, rotating it against a specified perpendicular surface (normally the gland face) and measuring the full indicated movement over several revolutions.

3.10

total radial run-out tolerance

tolerance zone limited by two coaxial cylinders, the defined radial distance apart, whose axes coincide with the datum axis

NOTE It can be measured by securing a dial indicator to the datum axis component (the shaft or seal chamber, depending on the tolerance zone to be recorded) and measuring the full indicated movement against the specified adjacent cylindrical surface over several revolutions.

4 Specification of dimensions of seal cavity and seal gland plate attachments

4.1 Dimensions of stuffing box and seal cavity attachments for general-purpose duties (designated ISO 3069-S)

The diameters shown in Figures 1, 2 and 3 shall have the values given in Table 1, and are intended to permit the use of either gland packing or mechanical seals.

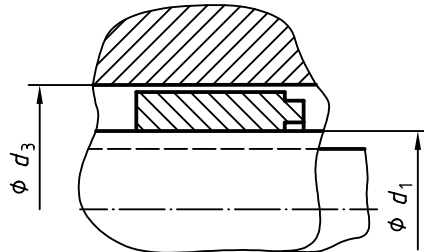

Figure 1 — Mechanical seal or soft packing with or without a sleeve

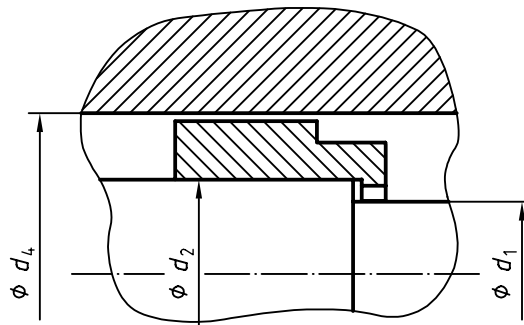

Figure 2 — Step-balanced mechanical seal with or without a short sleeve

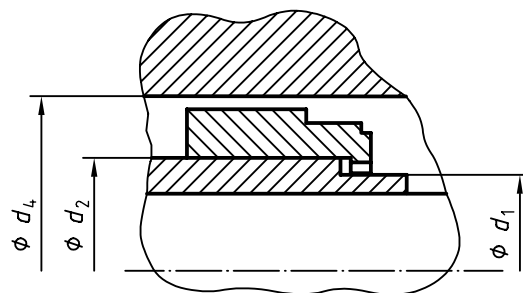

Figure 3 — Step-balanced mechanical seal with an extended sleeve

Table 1 — Stuffing box and seal cavity dimensions

Dimensions in millimetres

d_1 (h6) ^a	d_2 (h6)	Min. ^b d_3 ^c	Min. ^b d_4
18	22	34	38
20	24	36	40
22	26	38	42
24	28	40	44
25	30	41	46
28	33	44	49
30	35	46	51
32 ^d	38	48	58
33	38	49	58
35	40	51	60
38	43	58	63
40	45	60	65
43	48	63	68
45	50	65	70
48	53	68	73
50	55	70	75
53	58	73	83
55	60	75	85
58 ^d	63	83	88
60	65	85	90
63 ^d	68	88	93
65	70	90	95
68 ^d	—	93	—
70	75	95	104
75	80	104	109
80	85	109	114
85	90	114	119
90	95	119	124
95	100	124	129
100	105	129	134

^a h6 tolerance is not applicable to d_1 of Figure 2 and Figure 3.

^b Mechanical seal reliability is affected by the radial clearance between its rotating parts and the seal chamber bore. Arduous services such as those with significant solid content, or those that could result in excessive seal face temperature, should have a minimum 3 mm radial clearance. This is particularly important in the case of unflushed mechanical seals, for which conical shaping of the bore can additionally contribute to the performance of the seal.

^c H11 tolerance when used with soft packing.

^d Non-preferred sizes, should not be used for new designs.

Dimensions suitable for cartridge mechanical seals are shown in annex A.

Mechanical seals designed to meet the dimensions required by EN 12756 will fit the seal cavity ISO 3069-S.

4.2 Dimensions of seal cavity and seal gland plate attachments for heavy-duty process applications (designated ISO 3069-H)

The dimensions shown in Figures 4, 5 and 6 shall have the values given in Table 2.

NOTE The design is suitable for cartridge mechanical seals, but is unlikely to be available in pumps conforming to ISO 2858 because of its dimensional constraints.

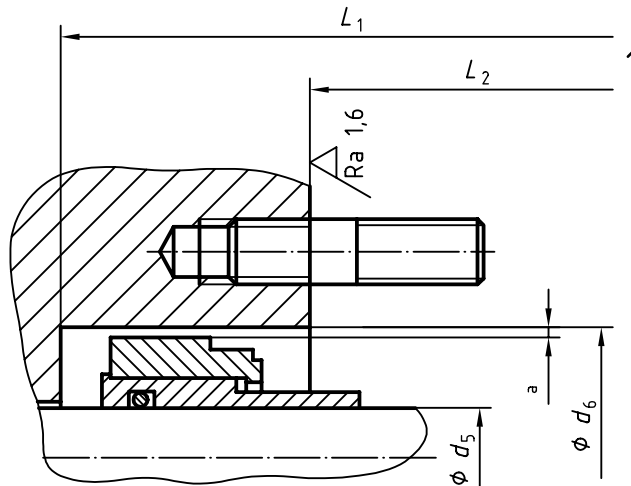

Key

- 1 To nearest obstruction
- a Minimum radial 3 mm

Figure 4 — Seal cavity

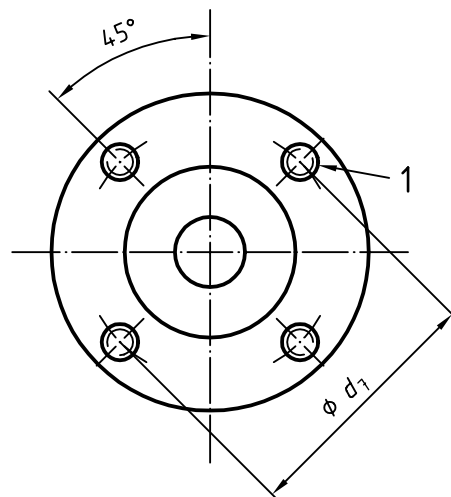

Key

- 1 4 off studs d_8

Figure 5 — Gland face and studs

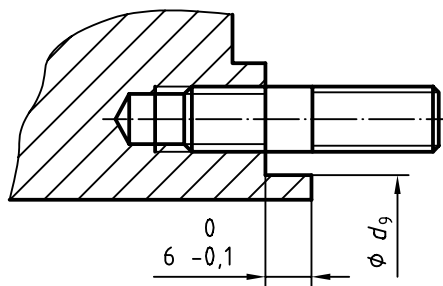

Figure 6 — Optional external spigot

Table 2 — Dimensions of seal cavity and seal gland plate attachments

Dimensions in millimetres

Max. d_5 (h6)	d_6 (H7)	d_7 ($\pm 0,5$)	d_8	d_9 (H7/f7)	Min. L_1	Min. L_2
20	70	105	M12 \times 1,75	85	150	100
30	80	115	M12 \times 1,75	95	155	100
40	90	125	M12 \times 1,75	105	160	100
50	100	140	M16 \times 2,0	115	165	110
60	120	160	M16 \times 2,0	135	170	110
70	130	170	M16 \times 2,0	145	175	110
80	140	180	M16 \times 2,0	155	180	110
90	160	205	M20 \times 2,5	175	185	120
100	170	215	M20 \times 2,5	185	190	120
110	180	225	M20 \times 2,5	195	195	120

NOTE 1 The gland plate should be radially located by an internal spigot in the bore dimension d_6 .

NOTE 2 An optional external spigot is shown in Figure 6.

5 Design requirements for seal cavities

5.1 Vent and drain

Mechanical seal reliability can be adversely affected by periods of operation in air or gas. Therefore the seal cavity shall include a means of eliminating trapped air or gas. Vent connections, when required for this purpose, shall be located at the highest point.

Process liquids can be hazardous or pollute the environment during disassembly. When a means of adequately draining the seal cavity is required, drain connections shall be located at the lowest practical point.

5.2 Squareness and concentricity of surfaces

Mechanical seal performance is influenced by the squareness and concentricity of the cavity and gland face surfaces.

The following tolerances shall not be exceeded.

- a) The seal gland plate concentricity to the shaft is controlled by the spigot diameter d_9 or the bore diameter d_3 , d_4 or d_6 depending on the cavity design. This surface shall have a total radial run-out tolerance not greater than 0,13 mm.
- b) The squareness of the gland face to the shaft axis can be checked by measuring its total axial run-out tolerance. The gland face shall have a total axial run-out tolerance not greater than 0,01 mm per 20 mm of seal chamber bore.
- c) Manufacture and assembly of the shaft and sleeve, if fitted, shall ensure that the total radial run-out tolerance, using the seal chamber as a datum, and at an axial position aligned with the gland face, conforms to ISO 9905, ISO 5199 and ISO 9908.

Annex A
(informative)

Dimensions of cavities for cartridge mechanical seals for general-purpose duties (designated ISO 3069-C)

Cartridge mechanical seals, utilizing proven metric seal assemblies, are difficult to fit in the stuffing box dimensions for general-purpose duties (see Table 1). The preference for spigot locations, and a rationalized seal gland plate, would be simplified by dimensional conformity of the gland face.

Figure A.1, A.2 and Table A.1 recommend dimensions suitable for fitting cartridge mechanical seals in centrifugal pumps designed for general-purpose duties, up to a seal chamber limit of a gauge pressure of 16 bar.

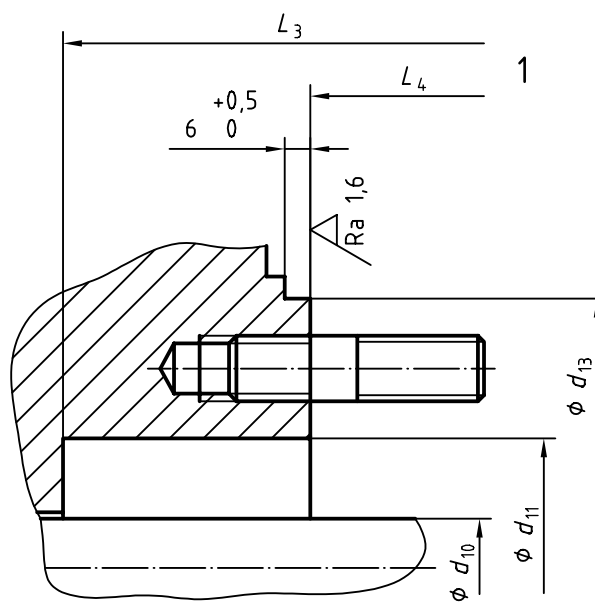

Key

- 1 To nearest obstruction

Figure A.1 — Seal cavity

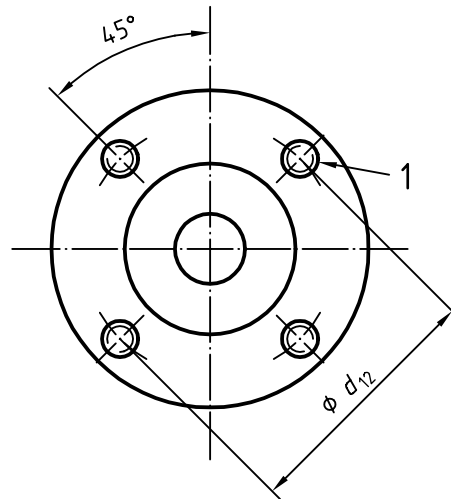
**Key**1 4 off studs d_{14} **Figure A.2 — Gland face and studs****Table A.1 — Dimensions of seal cavity and seal gland plate attachments**

Dimensions in millimetres

Max. d_{10} (h6)	d_{11}	d_{12} ($\pm 0,5$)	d_{13} (H7/f7) ^b	d_{14}	Min. L_3	Min. L_4
22	44	85	105	M10 \times 1,5 ^a	110	60
25	46	85	105	M10 \times 1,5 ^a	110	60
30	51	90	110	M10 \times 1,5 ^a	110	60
35	60	100	120	M10 \times 1,5 ^a	115	60
40	65	110	130	M12 \times 1,75	115	60
45	70	115	135	M12 \times 1,75	125	65
50	75	115	135	M12 \times 1,75	125	65
55	85	125	145	M12 \times 1,75	135	70
60	90	145	170	M16 \times 2,0	135	70
65	95	145	170	M16 \times 2,0	150	75
75	109	155	180	M16 \times 2,0	150	75
85	119	165	190	M16 \times 2,0	160	75

^a ISO 9905 and ISO 5199 recommend minimum stud size M12 unless impractical owing to space limitations.

^b Dimension d_{13} is positioned to permit an external spigot to radially locate the seal gland plate.

Bibliography

- [1] ISO 1101, *Geometrical Product Specifications (GPS) — Geometrical tolerancing — Tolerances of form, orientation, location and run-out.*
- [2] ISO 2858, *End-suction centrifugal pumps (rating 16 bar) — Designation, nominal duty point and dimensions.*

